

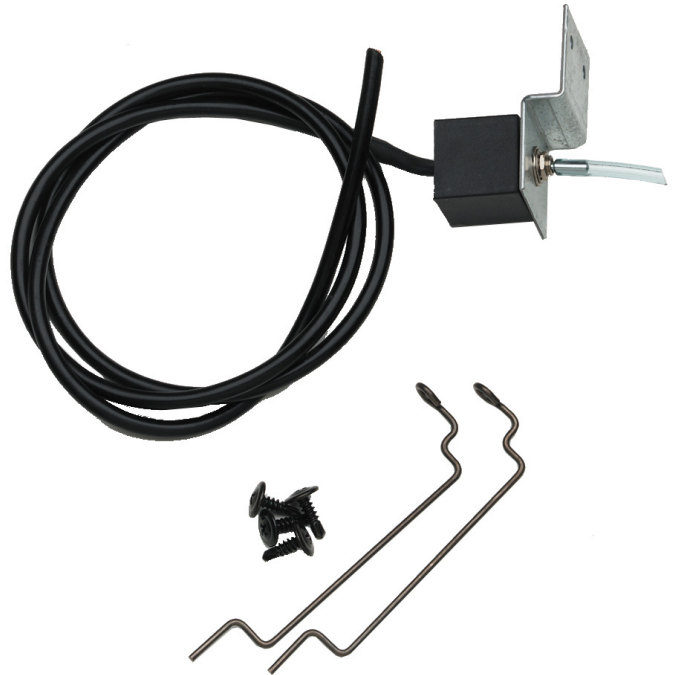

**MIKROBRYTARE**

**MICRO SWITCH**

**MICRO  
COMMUTATEUR**



*Part No. / Réf. / Art. Nr. / Cód.:*

**88400**

**Alentec & Orion AB** Grustagsvägen 4, SE-13840, Älta, SWEDEN · [Info@alentec.se](mailto:Info@alentec.se) · [alentec.com](http://alentec.com)

## Mounting instruction

1. Insert the circuit-breaker's feeler (1) into the hole (2).
2. Secure circuit-breaker using enclosed screws (3).
3. Check that the circuit-breaker can move freely in both directions.

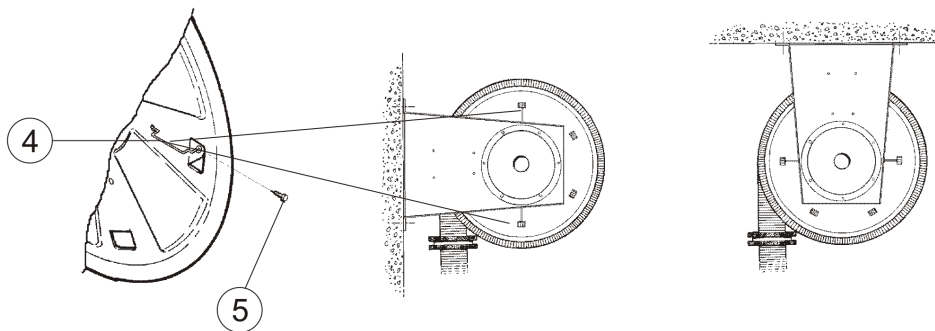
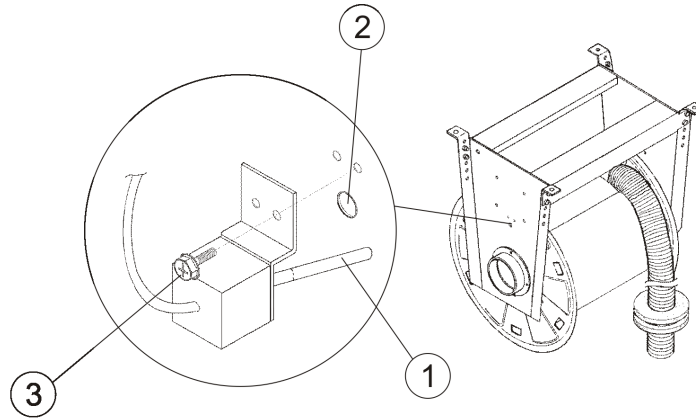

4. Pull out the hose and obtain 4 notches on one of the lock segments.
5. Mount the operating springs (4) (2 springs) on the drum by loosening 2 of the screws (5) that hold the drum, (N.B. mount springs according to diagram).
6. Refasten screws.

### 88400 used as a replacement for older model of 88400

When the 88400(2-pole) is used as an direct replacement for the older model of 88400(1-pole) the following conversions should be applied (on drawings describing the function/wiring of the 88400):

Older 88400 - Brown = New 88400 - Wire #1

Older 88400 - Black = New 88400 - Wire #2

or

Older 88400 - Brown = New 88400 - Wire #3

Older 88400 - Black = New 88400 - Wire #4

## Monteringsanvisning

1. För in strömbrytarens spröt (1) i hålet (2).
2. Skruva fast strömbrytaren med medföljande skruvar (3).
3. Kontrollera att strömbrytaren kan röra sig fritt åt båda hållen.

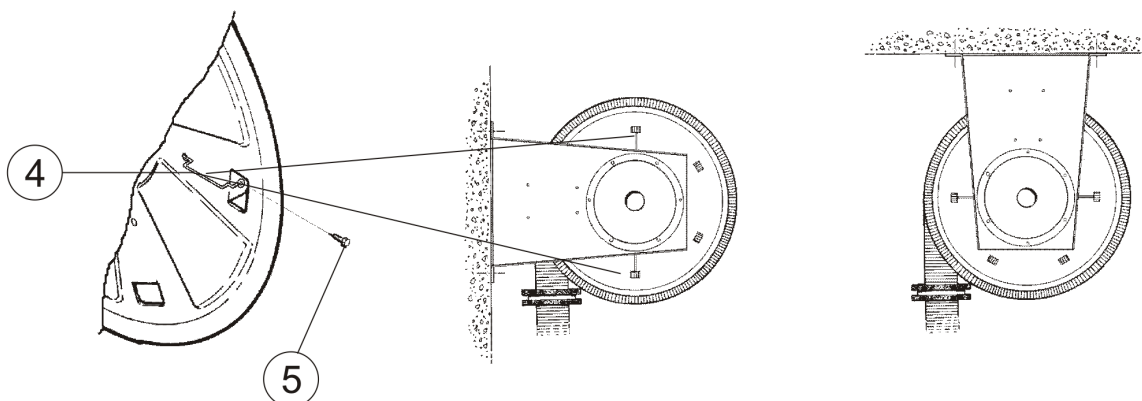
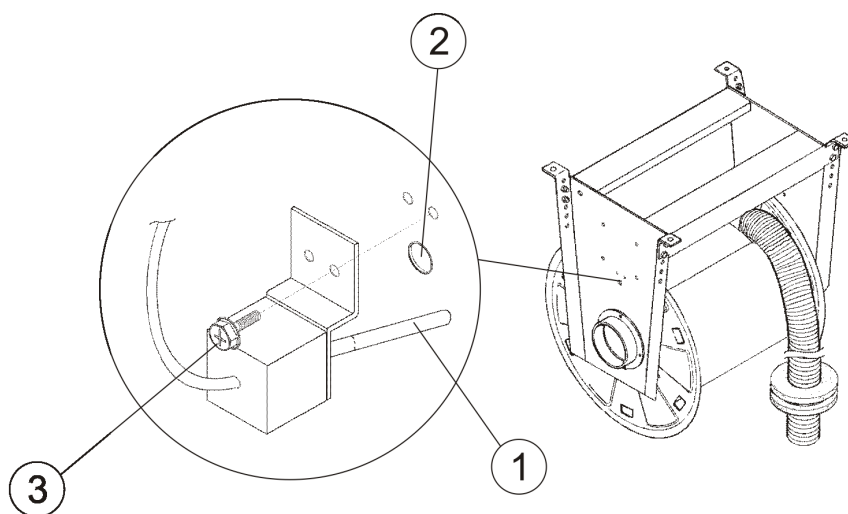

4. Drag ut slangen tills dess att fyra snäpp erhålles på ett av spärsegmenten.
5. Montera manöverbyglarna (4) (2st) på trumgaveln genom att lossa två av skruvarna (5) som håller trumman. OBS! Montera fjädrarna i hålen enligt skiss.
6. Skruva tillbaka skruvarna.
7. Manöverbygeln finns som reservdel; 838 00 49

### Ersättning av äldre modell 84000

När 84000 (2-polig) användes som direkt ersättning av äldre modell 84000 (1-polig) skall följande konverteringar iakttagas (på ritningar som beskriver funktion/inkoppling av 84000):

Äldre - Brun = Ny - Ledning #1

Äldre-24 - Svart = Ny - Ledning #2

eller

Äldre - Brun = Ny - Ledning #3

Äldre - Svart = Ny - Ledning #4

## Instructions de montage

1. Insérer la tige (1) du micro-contact dans le trou (2).
2. Fixer le micro-contact avec les vis fournies (3).
3. Vérifier que le micro-contact peut se déplacer librement dans les deux directions (marche/arrêt).

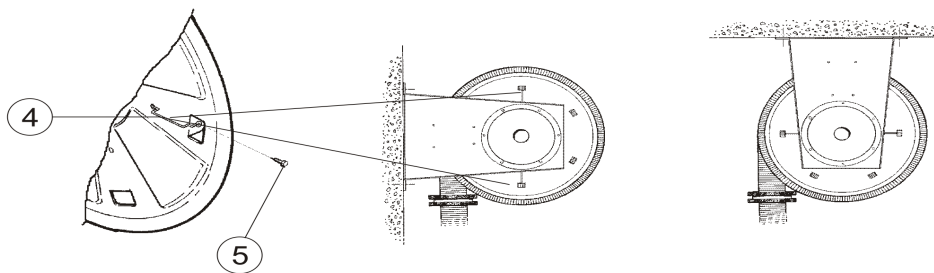
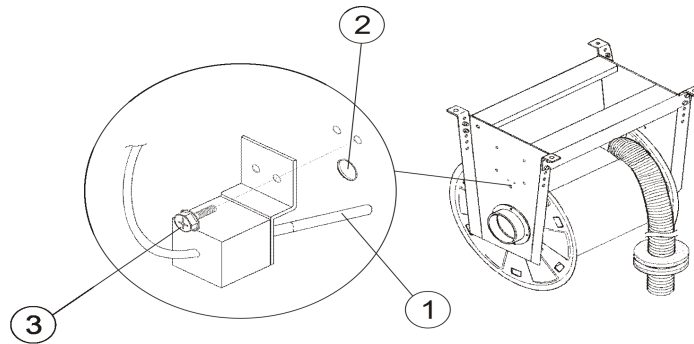

4. Dérouler le flexible.
5. Installer les deux ressorts (4) sur le tambour en desserrant deux des vis (5).  
Installer les ressorts selon le diagramme.
6. Resserrer les vis.

## Utilisation du 88400 en remplacement en åldre modell av 88400

Lorsque le MSR-24/2 est utilisé en remplacement du MSR-24, il faut appliquer les conversions suivantes pour les schémas décrivant les fonctions/câblages du MSR-24 :

MSR-24 – marron = MSR-24/2 – Câble n°1

MSR-24 – noir = MSR-24/2 – Câble n°2

ou

MSR-24 – marron = MSR-24/2 – Câble n°3

MSR-24 – noir = MSR-24/2 – Câble n°4

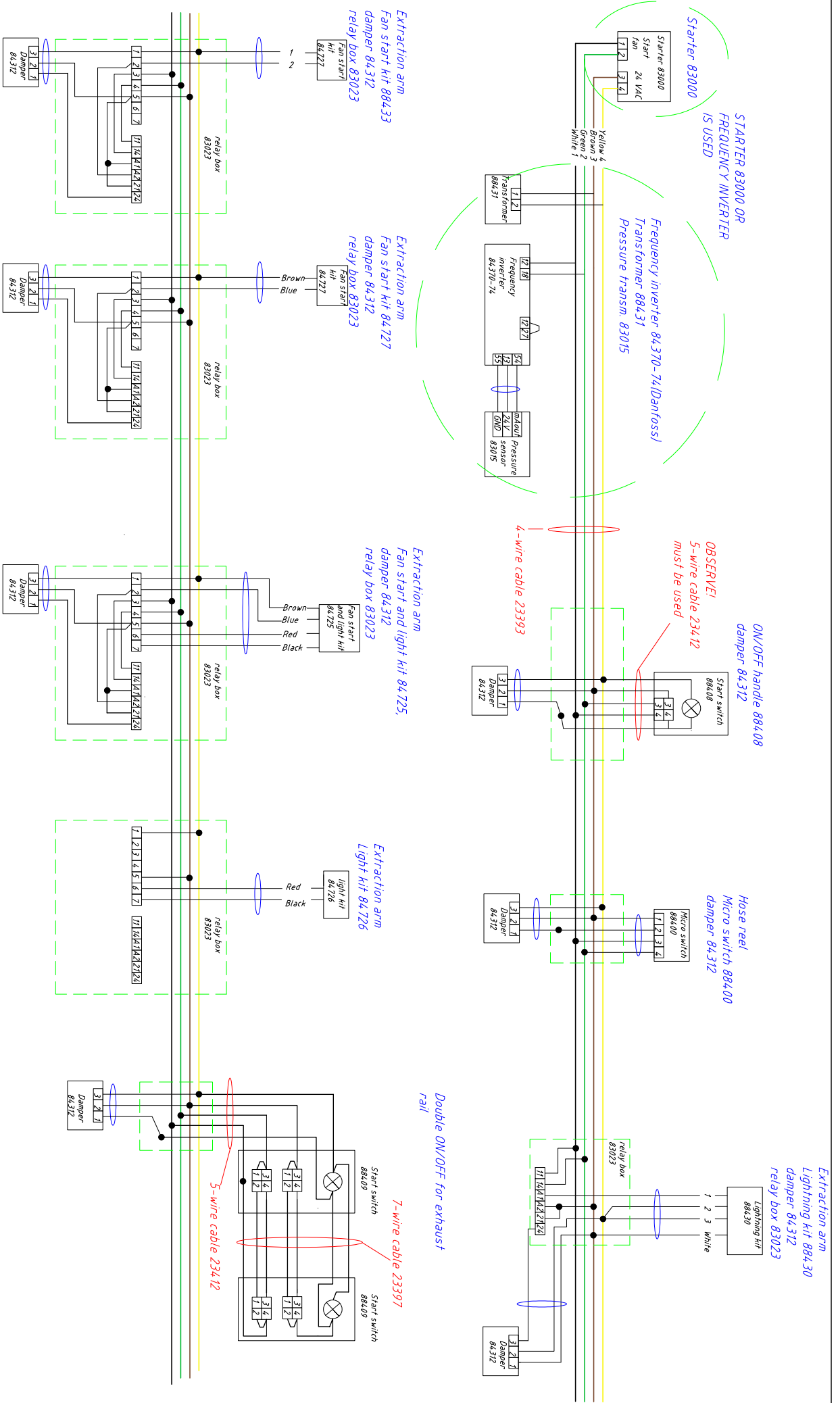

REV.	NO.	CHANGES	DATE	SIGN.
		<b>Exhaust connections</b>		
	83000			88430
	83470-74			88433
	88400			84727
	83023			84725
	88408			84726
	84312			88409

FILE NAME	REV.
Exhaust connections_Danfoss_Hdkwg	H

RESPONSIBLE	DATE OF ORG. CHECKED BY	DATE
DRAWN BY	2024-02-06	
SCALE	TYPE	

Alentec & Orion AB	
Grustagsvegen 4	
1384,0 Alta	
Tel: +46 (0)8 713 63 00	
Fax: +46 (0)8 715 20 70	
E-mail: info@alentic.se	
www.alentic.se	

# Connection to Frequency inverter, DCV, 84370-74

