

Parts and technical service guide  
 Guía de servicio técnico y recambios  
 Guide d'instructions et pièces de rechange  
 Bedienungsanleitung und Teilleiste  
 Manual de utilizagao e garantia  
 Список деталей и руководство по техническому обслуживанию

**METALLIC**  
**STAINLESS STEEL**

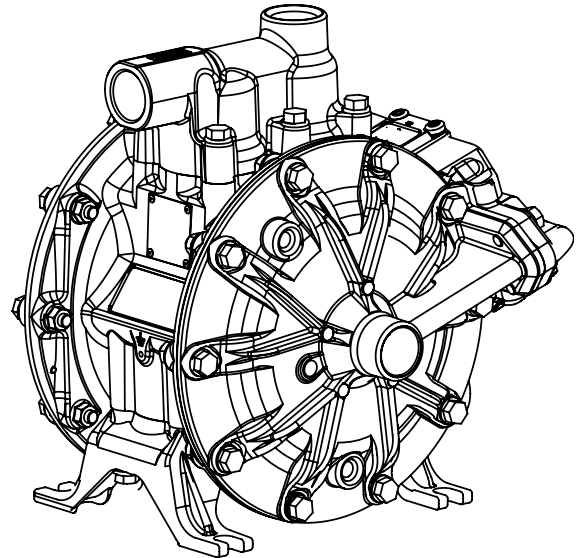

**METALLIC**  
**ALUMINIUM**

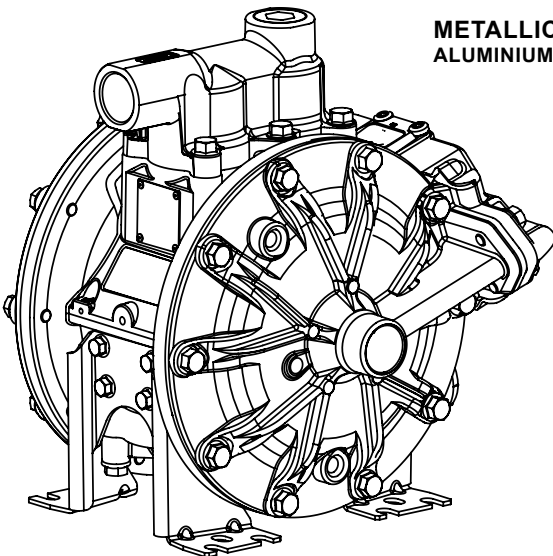

**NON-METALLIC**  
**POLYPROPYLENE**  
**CONDUCTIVE POLYPROPYLENE**  
**CONDUCTIVE ACETAL**  
**PVDF / CONDUCTIVE PVDF**

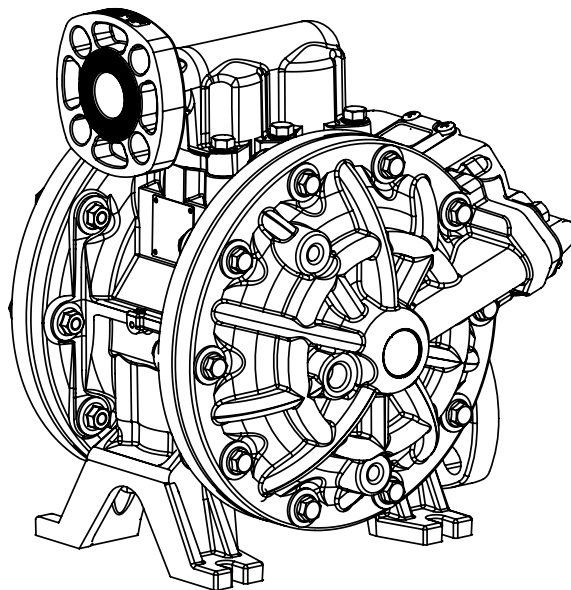

2021\_12\_15-12:00

# CODING / CODIFICACIÓN

	DP200	X	X	X	X	X	X	X	X
<b>EN</b>	<b>AIR VALVE / DISTRIBUIDOR AIRE</b>	<b>BODY PUMP / CUERPO COLECTORES</b>	<b>PUSH ROD / EJE</b>	<b>SEALS / SEATS / JUNTAS ASIENTOS</b>	<b>BALLS / BOLAS</b>	<b>DIAPHRAGMS / MEMBRANAS</b>	<b>CONNECTIONS / ROSCAS</b>	<b>OPTIONS / OPCIONES</b>	
<b>ES</b>	<b>A</b> Aluminum / Aluminio <b>P</b> Polypropylene / Polipropileno	<b>A</b> Aluminum / Aluminio <b>S</b> Stainless steel / Acero inoxidable <b>P</b> Polypropylene / Polipropileno <b>B</b> Conductive PP <b>C</b> POM <b>W</b> PVDF	<b>S</b> Stainless steel <b>Y</b> Hastelloy® C	<b>N</b> NBR <b>V</b> FKM <b>E</b> EPDM <b>T</b> PTFE <b>A</b> Aluminum / Aluminio <b>P</b> Polypropylene / Polipropileno <b>C</b> POM <b>W</b> PVDF <b>N</b> NBR <b>M</b> Santoprene® <b>H</b> Hytrel®	<b>T</b> PTFE <b>C</b> POM <b>S</b> Stainless steel / Acero inoxidable <b>N</b> NBR	<b>H</b> Hytrel® <b>T</b> PTFE <b>M</b> Santoprene® <b>N</b> NBR	<b>B</b> BSP <b>N</b> NPT <b>F</b> Flange	<b>A</b> Standard pump / Bomba estándar <b>B</b> Remote exhaust kit included / Kit salida de aire roscada incluido <b>C</b> Diaphragm leak detector / Detector de rotura de diafragma <b>D</b> Cycle sensor / Sensor de ciclos <b>E</b> Externally controlled with solenoid valve (not included) / Control externo con válvula de solenoido (no incluida) <b>F</b> Noise muffler included / Silencioso de nariz incluido <b>G</b> Externally controlled with solenoid valve (not included) and inductive end of stroke sensors NPN (included) / Control externo con válvula de solenoido (no incluida) y sensor de final de Carrera inductivos NPN (incluidos) <b>I</b> Externally controlled with solenoid valve (not included) and inductive end of stroke sensors ATEX-Namur (included) / Control externo con válvula de solenoido (no incluida) y sensor de final de Carrera inductivo ATEX -Namur- (incluidos) <b>U</b> Pump suitable for UV fluids / Bomba para fluidos UV	

## TECHNICAL DATA / DATOS TÉCNICOS

		<b>DP200</b>
RATIO	RATIO	<b>1:1</b>
MAXIMUM FREE FLOW	MÁXIMO CAUDAL SALIDA LIBRE	<b>53 Us gal/min (200 l/min)</b>
DELIVERY PER STROKE	DESPLAZAMIENTO POR EMBOLADA	<b>17 oz (0.5 l)</b>
AIR PRESSURE OPERATING RANGE	RANGO DE PRESIÓN	<b>20 to 120 psi (1,5 to 8 bar)</b>
SOLID IN SUSPENSION MAX SIZE	MAX. TAMAÑO DE PARTÍCULAS EN SUSPENSIÓN	<b>1/4" (6 mm)</b>
MAXIMUM SUCTION HEAD	ALTURA MÁXIMA DE SUCCIÓN	<b>16.5 ft (5 m) dry (seco), 26.2 ft (8 m) wet (húmedo)</b>
WEIGHT	PESO	<b>44.09 lb (20 kg) Stainless Steel (Acero inoxidable)</b>
		<b>24.25 lb (11 kg) Aluminum (Aluminio)</b>
		<b>23.1 lb (10,5 kg) Plastic (Plástico)</b>
FLUID INLET/ OUTLET CONNECTIONS	CONEXIONES DE ENTRADA/ SALIDA DE FLUIDO	<b>1" BSP (F) or NPT (F) Aluminum and Stainless steel pumps / (1" BSP (F) o NPT (F) Bombas de aluminio y acero inoxidable)</b>
		<b>FLANGE DIN DN25 or ANSI 1" B16.5 150 lbs BRIDA DIN DN25 o ANSI 1" B16.5 150 lbs</b>
AIR INLET	ENTRADA DE AIRE	<b>3/8" NPSM (F)</b>
TEMPERATURE RANGE	RANGO DE TEMPERATURAS DE TRABAJO	<b>32 -158 °F (0 - 70 °C)</b>

## CAPACITY CURVES / CURVAS DE CAPACIDAD

(oz, ft, gal/min) all in EEUU units

(oz, ft, gal/min) todo en unidades EEUU

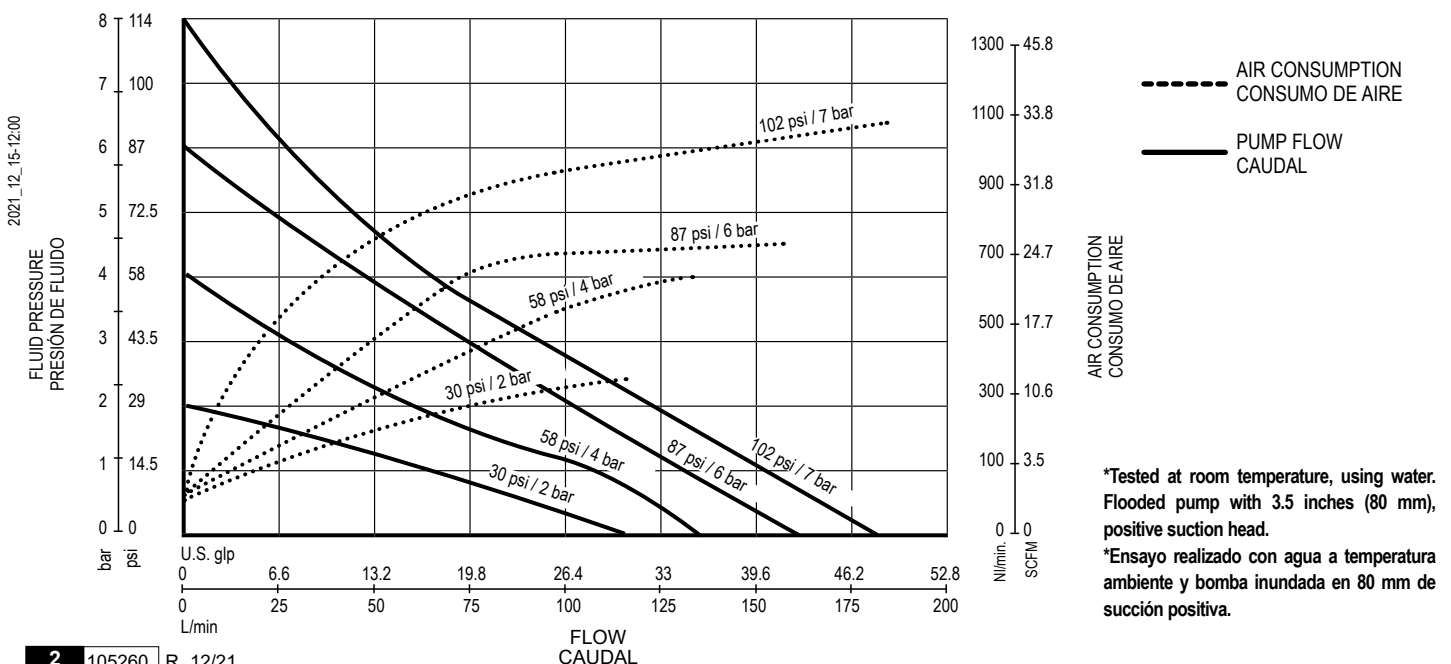

# DIMENSIONS / DIMENSIONES

## METALLIC-ALUMINIUM / METÁLICA-ALUMINIO

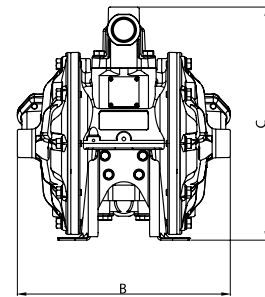
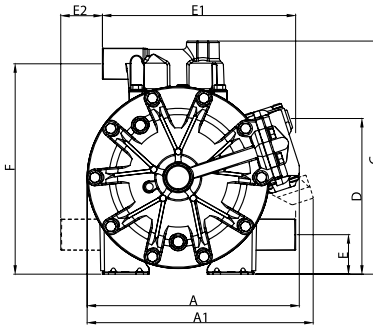
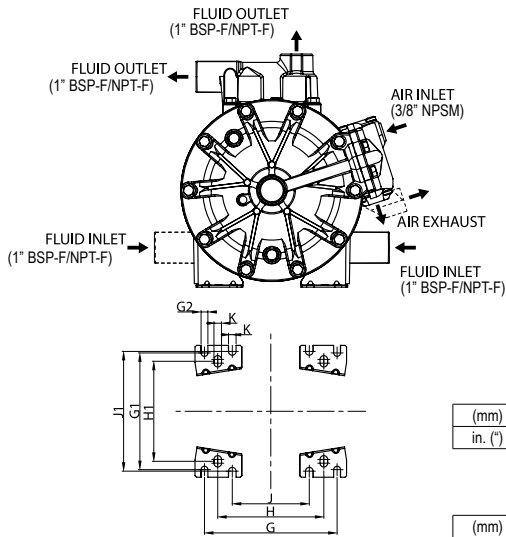

DIMENSIONS / DIMENSIONES

	A	A1	B	C	D	E	E1	E2	F
(mm)	280	298	281	308	205	52	255	55	278
in. (")	11 3/128"	11 47/64"	11 1/16"	12 1/8"	8 9/128"	2 3/64"	10 5/128"	2 21/128"	10 121/128"

ATTACHMENT / FIJACIONES

	G	G1	G2	H	H1	J	J1	K
(mm)	175	154	9	140	127-137	102	158	10
in. (")	6 57/64"	6 1/16"	23/64"	5 33/64"	5-5 25/64"	4 1/64"	6 7/32"	25/64"

## METALLIC-STAINLESS STEEL / METÁLICA-ACERO INOXIDABLE

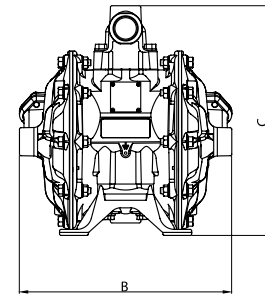
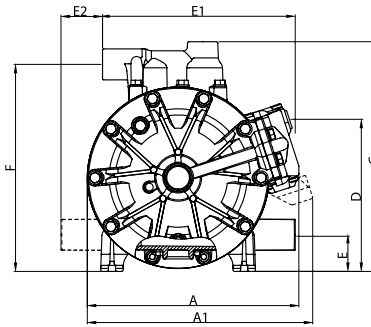
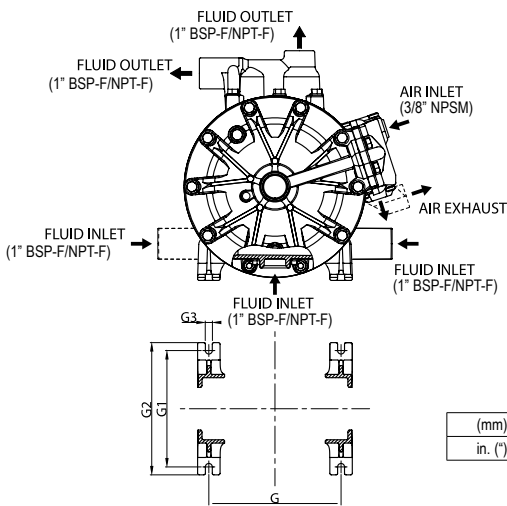

DIMENSIONS / DIMENSIONES

	A	A1	B	C	D	E	E1	E2	F
(mm)	280	298	281	304	200	48	255	55	274
in. (")	11 3/128"	11 47/64"	11 1/16"	11 31/32"	7 7/8"	1 57/64"	10 5/128"	2 21/128"	10 101/128"

ATTACHMENT / FIJACIONES

	G	G1	G2	G3
(mm)	175	154	175	9
in. (")	6 57/64"	6 1/16"	6 57/64"	23/64"

## NON METALLIC / NO METÁLICA

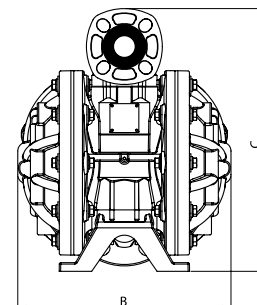
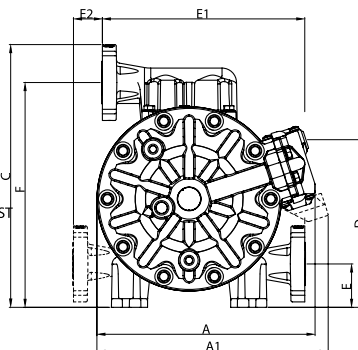
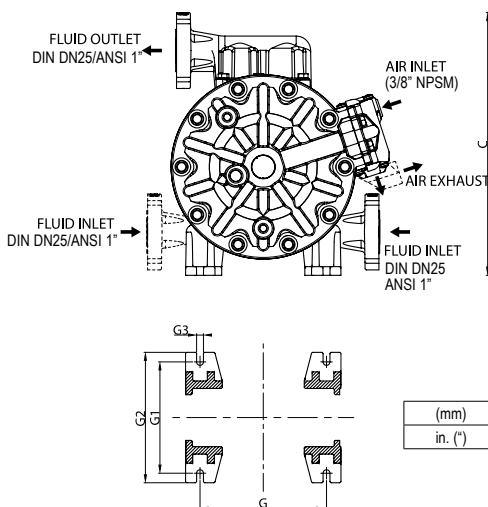

DIMENSIONS / DIMENSIONES

	A	A1	B	C	D	E	E1	E2	F
(mm)	302	320	295	364	232	60	280	40	311
in. (")	11 57/64"	12 19/32"	11 39/64"	14 21/64"	9 9/64"	2 23/64"	11 3/128"	1 37/64"	12 1/4"

ATTACHMENT / FIJACIONES

	G	G1	G2	G3
(mm)	175	154	180	9
in. (")	6 57/64"	6 1/16"	7 11/128"	23/64"

FLANGE / BRIDA

	Ø H	Ø I	J
(mm)	85	79,4	17
	3 11/32"	3 1/8"	43/64"

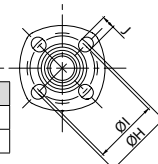

**IMPORTANT:** When doing a pump maintenance that implies manifold disassembling and pump is fitted with PTFE o-rings (white colour), they must be replaced by new ones in order to avoid fluid leakages".

**IMPORTANTE:** Cuando realice un mantenimiento en la bomba que implique desmontaje de los colectores y la bomba esté configurada con juntas de PTFE (color blanco), estas tienen que ser reemplazadas por unas nuevas con objeto de evitar fugas de fluido".

In this document you will find warnings and cautions for installation, use and maintenance of the pumps.  
Here's the meaning of symbols you may find in this document and general warnings that you should keep in mind.



**WARNING:** This symbol aware that there is a danger of serious bodily injury or death if you ignore the warning described.

**CAUTION:** This symbol aware that there is a danger of personal injury or property damage if you ignore the caution described.



**WARNING:** CAREFULLY READ THE INSTRUCTIONS AND WARNINGS BEFORE OPERATING THE EQUIPMENT!

- This equipment is for professional use only.
- Do not degrade the integrity of the equipment. Use only original replacement components from ALENTEC & ORION AB
- Fluids not suitable for the pump can cause damage to the pump unit and involve risk of serious personal injury. Always consult ALENTEC & ORION AB if you have any questions about the compatibility within the fluids and the pump materials, including elastomers.
- Install and use the pump according to all local and national regulations and abide all health and safety laws or legislation.
- The pump can produce fluid pressures equal to the air supply pressure. Do not exceed the maximum allowable pressure of 120 psi (8 bar) air supply. The total hydraulic pressure (differential pressure + system) should never exceed 120 psi (8 bar).
- Never use a pump that leaks, that is damaged, that is corroded or otherwise it may lack the capacity to contain the fluid.
- Frequently check that the bolts on the diaphragm cover of the pump are torqued correctly.
- Do not use a model with aluminium wetted surfaces to pump fluids for human consumption, there is a possibility of trace contamination of lead.
- Danger of explosion if used 1,1,1-trichloroethane, methylene chloride or other halogenated hydrocarbon solvents with aluminium wetted materials. It could cause serious injury and property damage.
- Inside the pump, diaphragms separate the fluid that is being pumped from the air supply. If a diaphragm breaks, the fluid can leak out of the air exhaust and contaminate the environment.
- When handling hazardous fluids, always route the air exhaust into a suitable container and locate it in a safe place. (Optional connection system at customer's request. Not supplied with the unit).
- When the fluid source level is situated higher than the pump, (flooded suction), the outlet tank must be at a higher level than the product to prevent spills.
- For pumps handling hazardous fluids that are a danger to humans or to the environment, install a suitable container surrounding the pump to prevent any leaks or spills.
- Ensure that the operators of this equipment are trained on the operation and limitations. Use safety equipment as safety goggles or other equipment required.

## DESCRIPTION

Air operated double diaphragm pumps are air-powered, reciprocating positive displacement pumps with two pumping chambers. Two diaphragms, centrally located in the chambers, separate the compressed air (dry side) from the fluid being pumped (wet side). A shaft transmits the reciprocating motion of one diaphragm to the other. A directional valve alternatively distributes the air from one chamber to the other; thus a reciprocating movement of the diaphragms is created. With each stroke, fluid is discharged by one of the diaphragms whilst the opposite diaphragm sucks new fluid into the expanding chamber. Check valves, two on the discharge side and two on the suction side, control and direct the fluid flow.

MATERIAL	TEMPERATURE RANGE
PTFE	5 °C - 105 °C / 41 °F - 221 °F
NBR	10 °C - 80 °C / 50 °F - 176 °F
Acetal	10 °C - 90 °C / 50 °F - 194 °F
Hytrel®	10 °C - 90 °C / 50 °F - 194 °F
Neopreno	-18 °C - 93 °C / 0 °F - 200 °F
Santoprene®	-29 °C - 135 °C / -20 °F - 275 °F
Viton®	-10 °C - 177 °C / -4 °F - 351 °F
Polypropylene	10 °C - 80 °C / 50 °F - 176 °F

## INSTALLATION

### INSTALLATION RECOMMENDATIONS

- Remove the pump from its package and install it on the chosen location.
- Try to minimize the suction head. Install the pump as close as possible to the fluid being pumped.
- Remember to have enough space around the pump to perform maintenance tasks.
- Keep in mind to connect the inlet and outlet of the pump correctly.
- In case of diaphragm pump failure, the air exhaust will expel the product being pumped.
- When the pump is installed in a place where a spill of fluid can cause an environmental impact, the exhaust should be directed to a place where this spill could be contained.
- When installing the pump in its place, use brackets to secure its base.
- Fasten all bolts with the torques contained in this manual.

# INSTALLATION

## DP PUMPS ARE VERY EASILY CONFIGURED AND EASY TO INSTALL

### FLOODED:

The pumping system was designed with positive pressure at the inlet. This is the best possible installation when you need to evacuate the liquid from the drum or tank, or when working with viscous fluids. Not recommended for hazardous fluids.

### SELF-PRIMING:

Pump is designed to generate vacuum. It is possible to evacuate all the air from a hose or pipe without damaging the pump. Maximum suction height is (5 m) 16.5 ft, with the suction hose empty and up to 8 m (26.25 ft) with the hose primed.

### SUBMERGED:

All pumps can be immersed in fluids. It is important to verify that all components that are in contact with the fluid are chemically compatible. In this case, air exhaust and fluid must be carried by hoses (optional air connection).

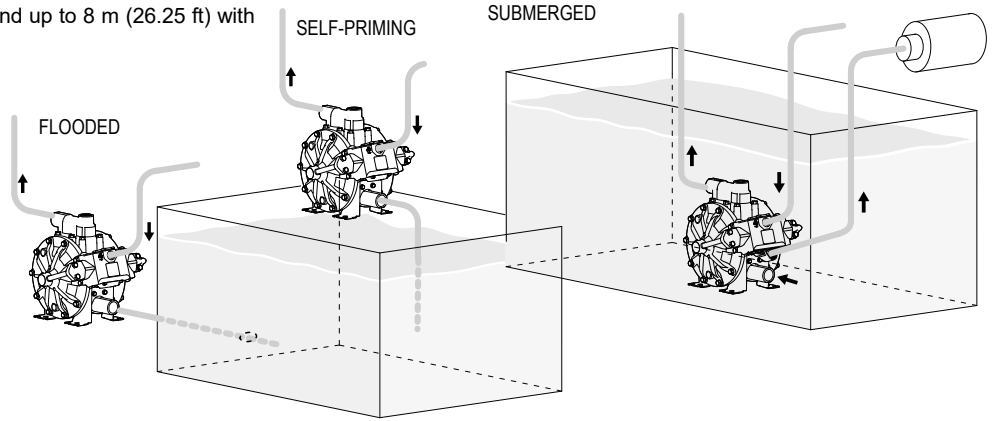

NOTE: Use a pressure regulator with built-in filter inlet.

NOTE: The compressed air supply must be between 1,5 bar (20 psi) and 8 bar (120 psi).

## RECOMMENDED INSTALLATION

The figure below shows the recommended configuration for the installation of a diaphragm pump. Read the warnings and recommendations of the previous page before starting.

### METALLIC

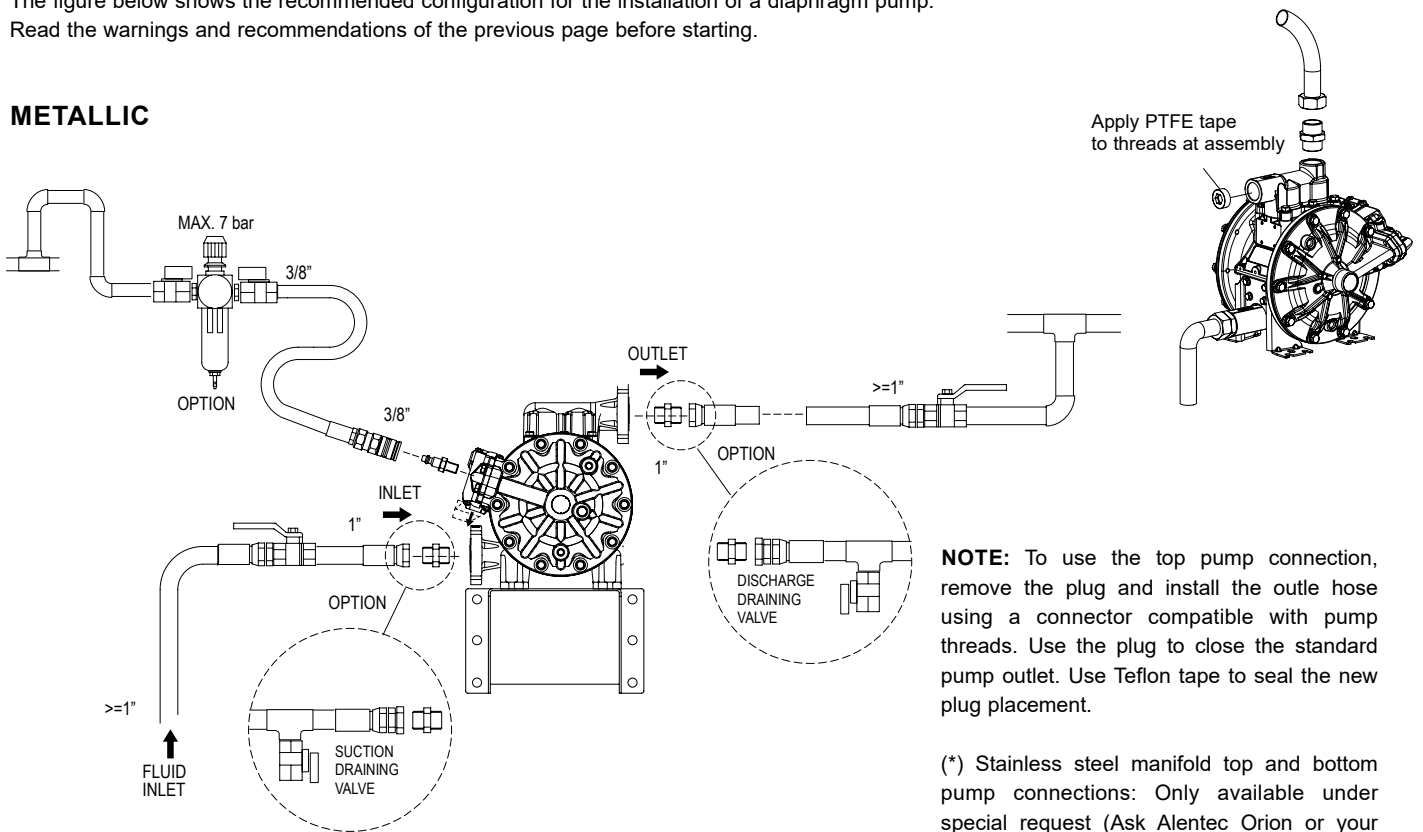

**NOTE:** To use the top pump connection, remove the plug and install the outle hose using a connector compatible with pump threads. Use the plug to close the standard pump outlet. Use Teflon tape to seal the new plug placement.

(\* ) Stainless steel manifold top and bottom pump connections: Only available under special request (Ask Alentec Orion or your local distributor).

2021\_12\_15-12:00

## RECOMMENDED INSTALLATION

The figure below shows the recommended configuration for the installation of a diaphragm pump. Read the warnings and recommendations of the previous page before starting.

## NON-METALLIC

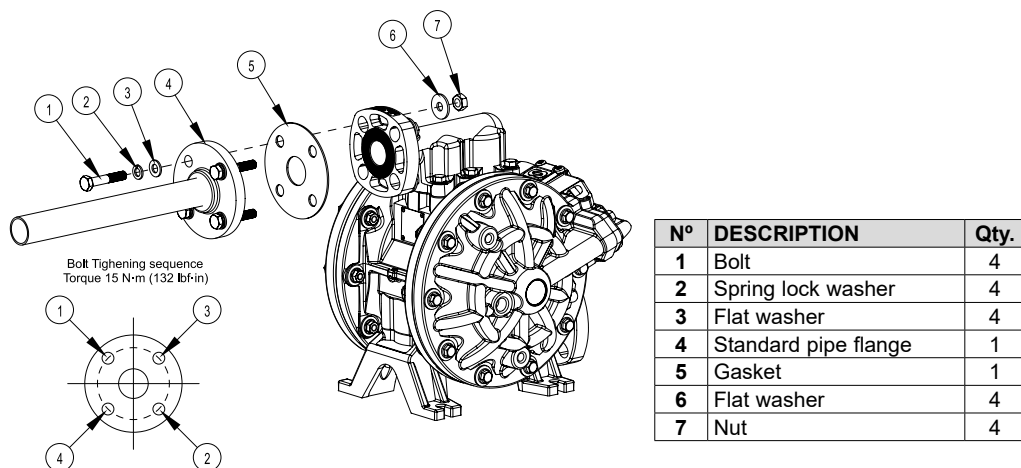

## AIR EXHAUST DISPOSAL

**WARNING**

- Optional kit is required for remote exhaust.
- Unscrew the 4 bolts and remove the standard muffler (pos. 1-10, pos. 1-12) in pump part drawing.
- Place the remote exhaust adaptor (pos. 1-41), (remember to install the included o-ring on its housing, (1-40). Screw the four bolts (pos. 1-42) previously removed.
- Connect a hose to the new exhaust port and install the muffler at the end of the hose. Use a hose with the same diameter as the exhaust port 3/4" NPT. (If the hose is more than 1.5 m (5 feet), consult your local distributor or ALENTEC & ORION AB).
- Have a moat, a protective housing, etc. at the end of the hose.

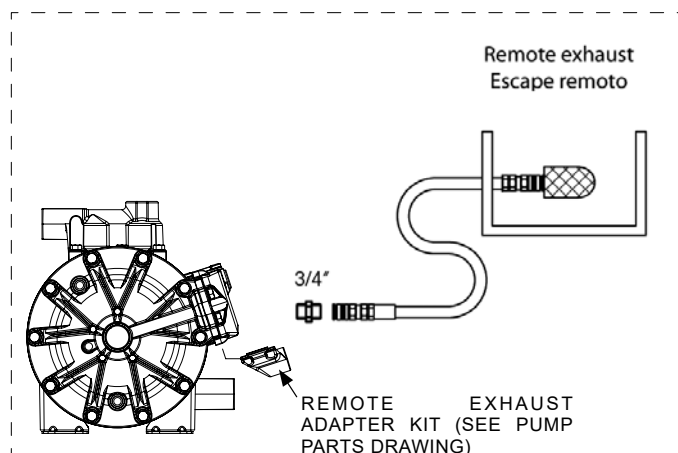

## AIR CONNECTION

- WARNING:** To ensure that the air supply is sufficient to meet the demand of the pump, the diameter of the pipe must be equal to the diameter of the supply port of the pump. Choose auxiliary air treatment equipment and fittings with sufficient airflow to exceed the air consumption of the pump. In addition, peripheral air treatment equipment must be installed as close as possible to the pump unit. The use of a coupler to connect the hoses aids future operation and maintenance tasks.

## OPERATING INSTRUCTIONS

### THIS PUMP IS SELF-PRIMING

To prime it the first time, you must connect the air pump supply to a low pressure using the pressure regulators while keeping the outlet valve open. When fluid begins to flow from the pump outlet, the pump is primed. For regulation of fluid pressure, the unit must be supplied with an air pressure between 1,5 and 8 bar (20 and 120 psi). Adjust the discharge valve on the discharge side to control flow. For the performance characteristics of the pump see the capacity curve.

### STOPPING THE PUMP FOR MAINTENANCE TASKS

- Stop the air supply.
- Make sure for your safety that the air valve is closed.
- Close the discharge valve and the suction valve. Open inlet and outlet drain valves.
- Open the air valve of the pump, running bring on the pump and flushing the remaining fluid.
- Close the air valve.
- After ensuring that the pump was turned off and the pressure was released, pump is ready for its maintenance.

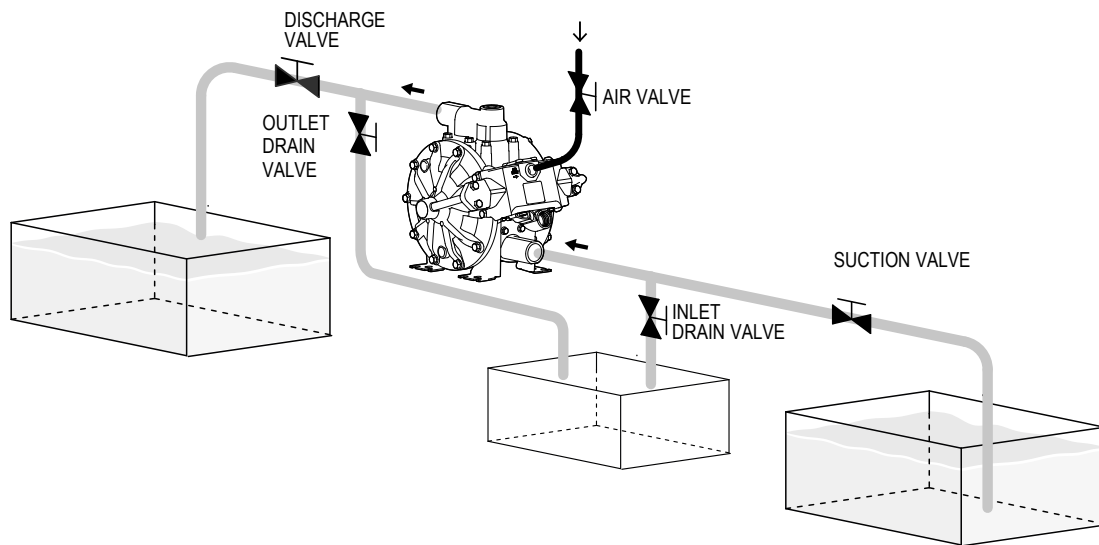

### GROUNDING THE PUMP

When installing the pump, be sure to perform grounding in the specified location.

Also connect ground wires for the auxiliary equipment and piping. Use a grounding cable of at least 12 gauge (2.0 mm<sup>2</sup>).

If the pump you have purchased is valid for ATEX, a specific ATEX manual will accompany this one. Read this manual before operating the pump.

If the unit is marked with the symbol  $\text{Ex}$ , it can be used in potentially explosive atmospheres. Below this symbol, in the nameplate of the pump, are indicated the areas for which the equipment is approved. You will also find the maximum allowable surface temperature in the same plate.



#### WARNING

Connect grounding wires to the pump, piping and all other equipment too.

When the pump operates ungrounded or with an incorrect connection, friction between parts and abrasion caused by some fluids that flow inside the pump, can generate static electricity. Moreover, according to the type of fluid pump and the installation environment (such as gases in the air or the type of the surrounding facilities) static electricity can cause fire or electric shock.

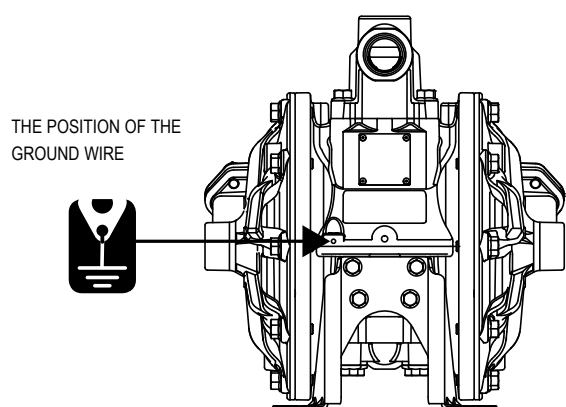

2021\_12\_15-12:00

METALLIC PUMP PARTS DRAWING

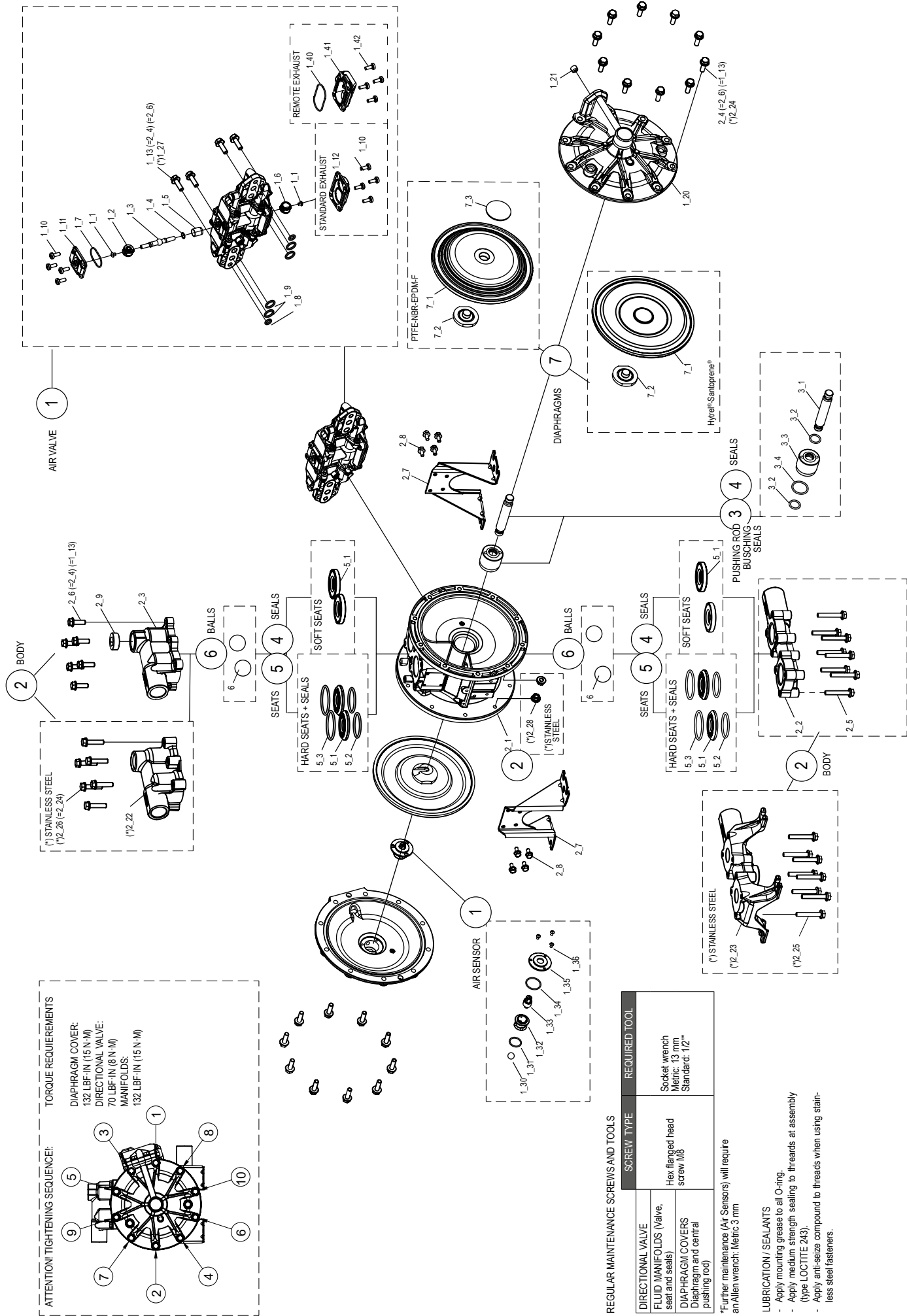

**ATTENTION! TIGHTENING SEQUENCE:**

**TORQUE REQUIREMENTS**

DIAPHRAGM COVER:  
132 LBF-IN (15 N-M)

DIRECTIONAL VALVE:  
70 LBF-IN (8 N-M)

MANIFOLDS:  
132 LBF-IN (15 N-M)

**REGULAR MAINTENANCE SCREWS AND TOOLS**

SCREW TYPE	REQUIRED TOOL
DIRECTIONAL VALVE FLUID MANIFOLDS (Valve, seat and seals)	Socket wrench Metric: 13 mm Standard: 1/2"
DIAPHRAGM COVERS Diaphragm and central pushing rod)	Hex flanged head screw lift

\*Further maintenance (Air Sensors) will require an Allen wrench: Metric 3 mm

**LUBRICATION / SEALANTS**

- Apply mounting grease to all O-ring.
- Apply medium strength sealing to threads at assembly (type LOCTITE 243).
- Apply anti-seize compound to threads when using stainless steel fasteners.



# METALLIC PUMP

DP200	X	X	X	X	X	X	X	X	X	X	X
	1	2	3	4	5	6	7	8	9		
<b>AIR VALVE</b> AA Aluminum	<b>BODY PUMP</b> A Aluminum S Stainless steel	<b>PUSH ROD</b> S Stainless steel	<b>SEALS</b> N NBR V FKM E EPDM T PTFE	<b>SEATS</b> S Stainless steel A Aluminum P Polypropylene N NBR M Santoprene® H Hytrel®	<b>SEATS</b> S Stainless steel A Aluminum P Polypropylene N NBR M Santoprene® H Hytrel®	<b>BALLS</b> T PTFE C POM S Stainless steel N NBR	<b>DIAPHRAGMS</b> H Hytrel® T PTFE M Santoprene® N NBR	<b>CONNECTIONS</b> B BSP N NPT	<b>OPIONS</b> A Standard pump B Remote exhaust kit included C Diaphragm leak detector D Cycle sensor E Externally controlled with solenoid valve (not included) F Nose muffler included G Externally controlled with solenoid valve (not included) and inductive end of stroke sensors NPN (included) I Externally controlled with solenoid valve (not included) and inductive end of stroke sensors ATEX-Hamur (included) J Pump suitable for UV fluids		

1		AIR VALVE	
<b>AIR VALVE</b>	<b>AIR SENSORS</b>	<b>REMOTE EXHAUST</b>	
POS 1_1 to 1_13	POS 1_30 to 1_36	POS 1_40 to 1_42	
A	58525	58562	

2				CENTRAL BODY AND MANIFLOD			
<b>CENTRAL BODY</b>	<b>INLET MANIFLOD</b>	<b>OUTLET MANIFLOD</b>					
POS 2_1	POS 2_2	POS 2_3					
A	755123.001	BSP THREADS	NPT THREADS	BSP THREADS	NPT THREADS		
S	855052	755126.301	755125.001	755125.301	755125.301		
		855054.300	855053	855053.300	855053.300		

3		PUSH ROD REPAIR KIT	
<b>PUSH ROD</b>	<b>SEALS</b>	<b>KIT CODE</b>	<b>NUMERICAL CODING 2233X</b>
S	V	58556	-
S	E	58557	-
S	T	58566	-
S	N	58554	555010/555030

4		SEATS VALVE REPAIR KIT	
<b>SEATS</b>	<b>SEALS</b>	<b>KIT CODE</b>	<b>NUMERICAL CODING 2233X</b>
A	N	58539	-
A	V	58540	-
A	E	58541	-
A	T	58542	-
S	T	58551	-
N		58535	555030
H		58552	555010
M		58553	-

6		BALL VALVE REPAIR KIT	
	<b>KIT CODE</b>	<b>NUMERICAL CODING 2233X</b>	
T	58529	-	
C	58528	551010/555030	
S	58530	-	
N	58531	-	

7		DIAPHRAGMS	
	<b>KIT CODE</b>	<b>NUMERICAL CODING 2233X</b>	
H	58521	555010	
M	58523	-	
N	58561	555030	
T	58522	-	

## TECHNICAL CHARACTERISTICS LABEL



**MODEL:**  
 2233X (numerical coding)  
 DP200XXXXXXXXXX (alphanumeric coding)

NON-METALLIC PUMP PARTS DRAWING

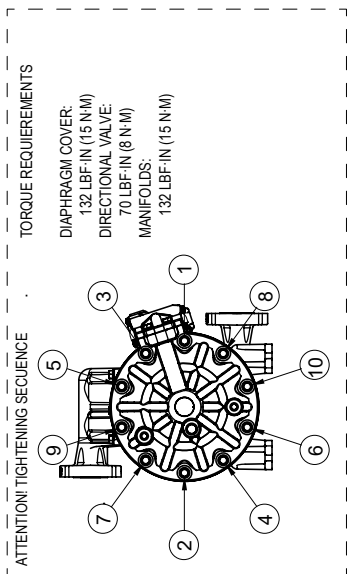

ATTENTION! TIGHTENING SEQUENCE

TORQUE REQUIREMENTS

- DIAPHRAGM COVER:  
132 LBF-IN (15 N.M)
- DIRECTIONAL VALVE:  
70 LBF-IN (8 N.M)
- MANIFOLDS:  
132 LBF-IN (15 N.M)

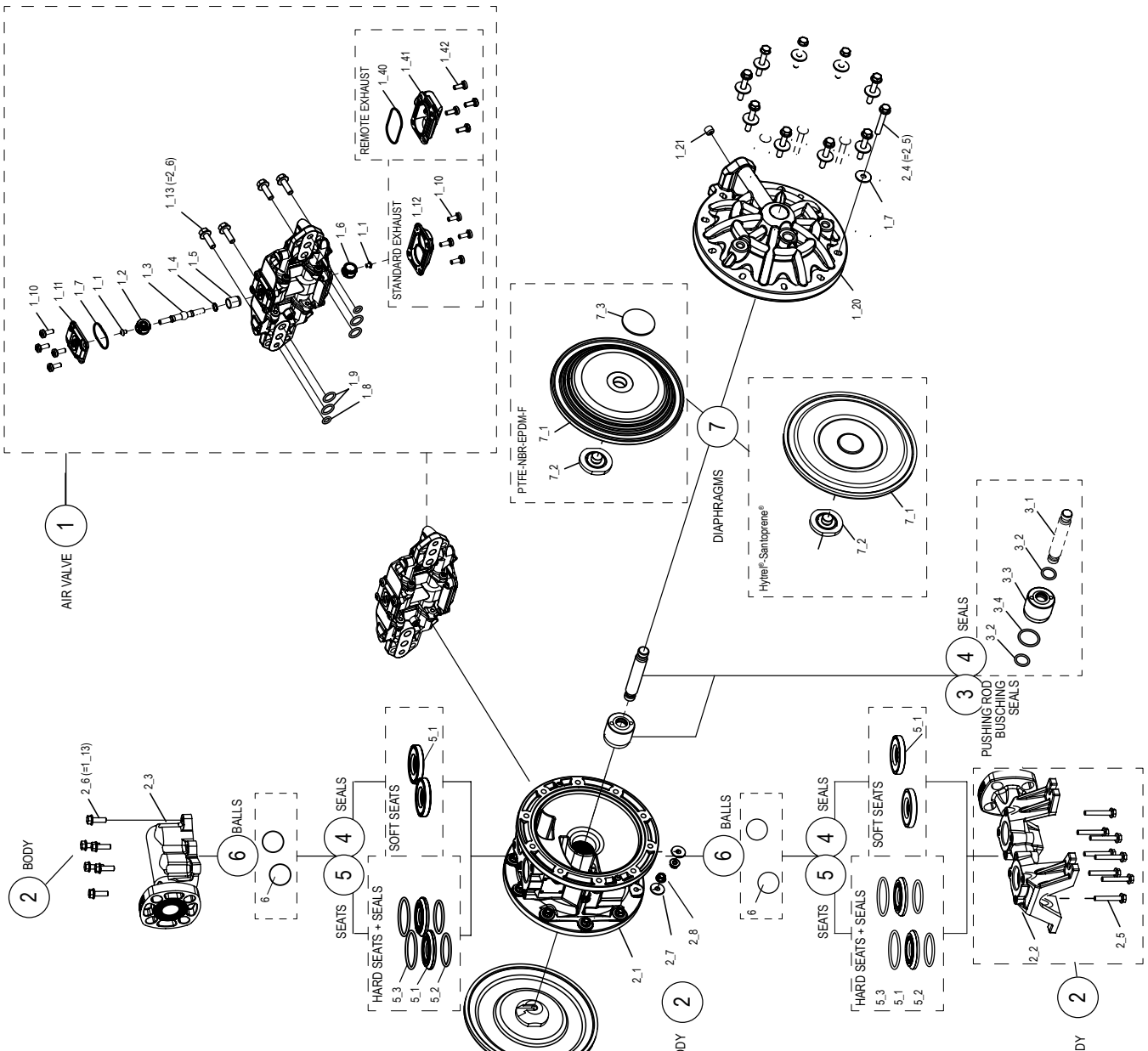

REGULAR MAINTENANCE SCREWS AND TOOLS

SCREW TYPE	REQUIRED TOOL
DIRECTIONAL VALVE	
FLUID MANIFOLDS (Valve, seat and seals)	Socket wrench Metric: 13 mm Standard: 1/2"
DIAPHRAGM COVERS (Diaphragm and central pushing rod)	Hex flanged head screw M6

\*Further maintenance (Air Sensors) will require an Allen wrench: Metric 3 mm

LUBRICATION / SEALANTS

- Apply mounting grease to all O-ring.
- Apply medium strength sealing to threads at assembly (type LOCTITE 243)
- Apply anti-seize compound to threads when using stainless steel fasteners.

# NON-METALLIC PUMP

DP200	X	X	X	X	X	X	X	X	X	X	X
	1	2	3	4	5	6	7	8	9		
<b>AIR VALVE</b> P Polypropylene	<b>BODY PUMP</b> P Polypropylene B Conductive PP W PVDF	<b>PUSH ROD</b> S Stainless steel Y Hastelloy® C	<b>SEALS</b> N NBR V FKM E EPDM T PTFE	<b>SEATS</b> P Polypropylene C POM W PVDF M Santoprene® H Hytrel®	<b>T PTFE</b> C POM S Stainless steel N NBR	<b>BALLS</b> H Hytrel® T PTFE M Santoprene® N NBR	<b>DIAPHRAGMS</b> F Flange	<b>CONNECTIONS</b>	<b>OPTIONS</b> A Standard pump B Remote exhaust kit included C Diaphragm leak detector D Cycle sensor E Externally controlled with solenoid valve (not included) F Nose muffler included G Externally controlled with solenoid valve (not included) and inductive end of stroke sensors NPN (included) I Externally controlled with solenoid valve (not included) and inductive end of stroke sensors ATEX-Namur (included) U BP ump suitable for UV fluids		

1		AIR VALVE		REMOTE EXHAUST	
P	POS 1_1 a 1_13 558525	POS 1_30 a 1_36 558527	POS 1_40 a 1_42 558562		

2		CENTRAL BODY AND MANIFLOD			
CENTRAL BODY		INLET MANIFLOD		OUTLET MANIFLOD	
P	POS 2_1 755552	POS 2_2 896642	POS 2_3 755560	BRIDA DIN/ANSI	BRIDA DIN/ANSI
B	755553	896643	894637		
W	755556	896646	755561		

3		PUSH ROD REPAIR KIT			
PUSH ROD	SEALS	CÓD. KIT	NUMERICAL CODING 2233X		
S	V	ATEX PUMP 558556	NO ATEX PUMP 558555	-	555164
S	E	558557	558558	-	-
S	T	558566	558560	-	-
Y	T	558559	-	-	-

4		SEATS VALVE REPAIR KIT			
SEATS	SEALS	KIT CODE	NUMERICAL CODING 2233X		
P	V	558544	558545	-	555164
P	E	558546	558536	-	-
P	T	558537	558538	-	-
C	V	558537	558548	-	-
C	E	558538	558552	-	-
C	T	558548	558553	-	-
W	T	-	-	-	-
H	-	-	-	-	-
M	-	-	-	-	-

6		BALLS VALVE REPAIR KIT	
	KIT CODE	NUMERICAL CODING 2233X	
T	558529	558528	555164
C	558528	558530	-
S	558530	558531	-
N	558531	-	-

7		DIAPHRAGMS	
	KIT CODE	NUMERICAL CODING 2233X	
H	558521	558523	555164
M	558523	-	-
N	558561	-	-
T	(1) 558522 (2) 558567	-	-

(1) For pump fitted with stainless steel central pushing rod.  
(2) For pump fitted with hastelloy® C central pushing rod.

## TECHNICAL CHARACTERISTICS LABEL

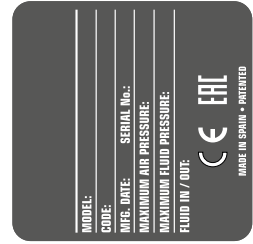

MODEL: 2233X (numerical coding)  
DP200XXXXXXXXXX (alphanumeric coding)

CAUSE	RECOMMENDED MEASURE
<b>THE PUMP DOES NOT WORK</b>	
The discharge valve on the discharge side is not open.	Open the discharge valve on the discharge side.
No air supply.	Turn on the compressor and open the air valve and air regulator.
The air supply pressure is low.	Check the compressor and the configuration of the air line.
Air leaks in connecting elements.	Check the connection elements and the tightening of the screws.
The air pipes or ancillary equipment is clogged with mud.	Check and clean the air line.
The exhaust port (muffler) of the pump is clogged with mud.	Check and clean the exhaust port and muffler.
The fluid pipe is clogged with mud.	Check and clean the fluid line.
Pump is clogged with mud.	Remove, inspect and clean the pump body.

<b>THE PUMP RUNS BUT NO FLUID COMES OUT</b>	
The valve on the suction side is not open.	Open the valve on the suction side.
Too much suction or discharge height.	Confirm the configuration of the pipe and reduce the height of the same.
Fluid pipe discharge side (including the filter) is clogged with mud.	Check and clean the fluid line.
Pump is clogged with mud.	Dismantle the pump, check and clean.
The ball and ball seat is worn or damaged.	Inspect and replace parts.

<b>THE FLOW IS DECREASING</b>	
The air supply pressure is low.	Check the compressor and the configuration of the air line.
The air line or peripheral equipment clogged with mud.	Check and clean the air line.
Valve discharge side drive will not open normally.	Adjust the discharge valve discharge side.
The air mixes with the fluid.	Replenish fluid and check the configuration of the pipe on the suction side.
Cavitation occurs.	Adjust air supply pressure and discharge pressure and reduce the suction.
Vibrations.	Adjust air supply pressure and discharge pressure. Reduce the flow of the inlet valve to adjust pressure and volume of fluid.
Ice formation in the air exhaust.	Remove ice from the air bypass valve and check and clean the air filter. Use a pipe in the exhaust air that the ice does not form in the muffler.
The fluid line (including the filter) plugged with mud.	Check and clean the fluid pipe and strainer.
The exhaust port (muffler) of the pump is clogged with mud.	Check and clean the exhaust port and muffler.
Pump is clogged with mud.	Remove, inspect and clean the pump body.

<b>LEAKAGE OF FLUID THROUGH THE HOLLOW EXHAUST (SILENCER)</b>	
The diaphragm is damaged.	Remove and inspect the pump and replace the diaphragm.

<b>IRREGULAR NOISE</b>	
The air supply pressure is too high.	Adjust air supply pressure.
The pump is clogged with sludge particles larger than the diameter allowed.	Remove, check and clean the pump body.

<b>IRREGULAR VIBRATION</b>	
The elements of connection and the support of the pump are loose.	Review each element of connection and tighten the screws.
The air supply pressure is too high.	Adjust air supply pressure.
The range and ball valve vibrates.	Adjust air supply pressure and exhaust pressure.

<b>IN FLUID WITH AIR BUBBLES</b>	
Diaphragm damaged.	Replace diaphragm.
Suction hose loose or broken.	Tighten or replace.

<b>POWERED AIR LEAK PRESSURE OF 1,5 TO 8 BAR (20 TO 120 PSI)</b>	
Wear air valve.	Replace air valve.

<b>NO START-UP AND IS LEAKING AIR WITHOUT CYCLES</b>	
Stiff air sensors.	Change air sensor.
Wear air valve.	Replace.

# REPAIR AND MAINTENANCE PROCEDURES

## TORQUES NECESSARY FOR THE PROPER FUNCTIONING OF THE PUMP

For proper operation of the pump and to prevent accidents which may damage equipment and in the worst case, people, you must periodically review the torques of the diaphragms covers and the DIRECTIONAL VALVE. In the next table are shown the appropriate torques for this purpose:

TORQUES DP200		
	Diaphragm cover	132 lbf-in ( 15 N·m)
	Directional valve	70 lbf-in ( 8 N·m)
	Manifolds	132 lbf-in (15 N·m)

**⚠ CAUTION!:** DO NOT OVERTIGHTEN FASTENERS.

### DIAPHRAGM MAINTENANCE

Before any intervention: DISCONNECT AIR SUPPLY OF THE PUMP.  
IT IS NOT NECESSARY TO REMOVE THE PUMP FROM THE FLUID LINE.  
ANTICIPATE A POSSIBLE LEAKAGE OF FLUID INSIDE THE PUMP.

### REMOVING THE DIAPHRAGM:

1. Close inlet and discharge fluid valves.
2. Drain the fluid inside the pump.
3. Remove the directional valve while being careful not to damage the seals between air valve and diaphragm.
4. Remove the diaphragm cover screws.  
**NOTE: To tighten these screws you must use a torque wrench calibrated to (see torque table in this page).**
5. Remove the cover by gently pulling back.
6. Remove the used diaphragms.

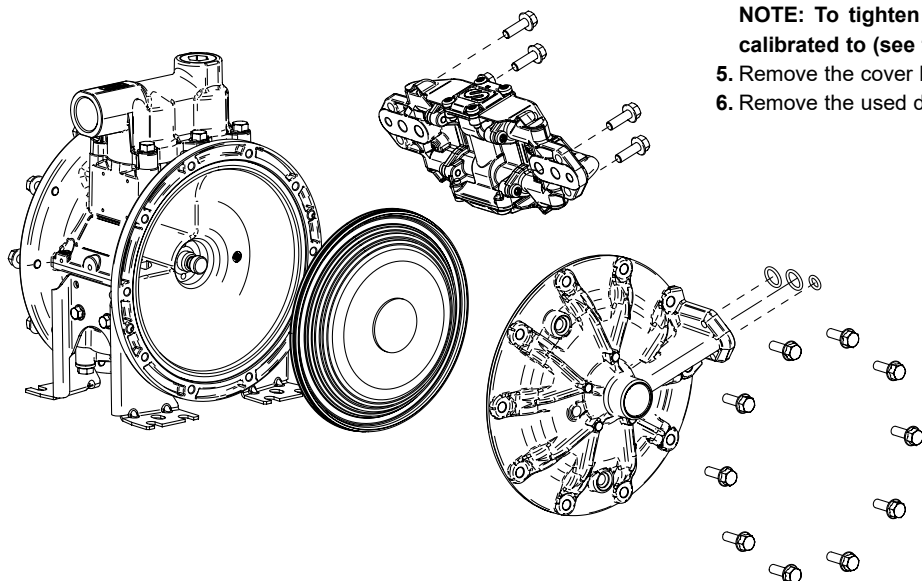

**NOTE:** Be careful to not lose the seals between valve and diaphragm cover.

### INSTALLING THE NEW DIAPHRAGMS - ASSEMBLING PROCEDURE

**⚠ CAUTION:** Follow next procedure to ensure the diaphragms are correctly installed. If not followed diaphragm bead could be extruded out of its housing with the resulting damage over the diaphragm bead and thus possible fluid leaks or premature diaphragm failure.

1. PREPARING THE CENTRAL ROD FOR DIAPHRAGM INSTALLATION  
Using a soft head hammer displace the central rod out of the body enough to install the diaphragm without deforming it.

Avoid install the diaphragm without preparing the central rod in its proper position. Diaphragm bead could be damaged when installing diaphragm cover.

**⚠ CAUTION!**

1. Correct assembly of the diaphragm before the diaphragm cover assembly.

2. Incorrect assembly of the diaphragm. Possible damage when assembling the diaphragm cover.

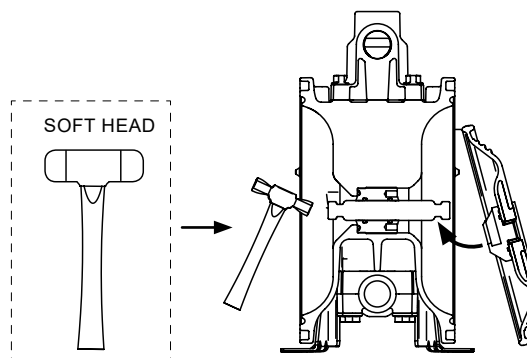

2021\_12\_15-12:00

2. FIRST DIAPHRAGM ALIGNMENT

Using the soft head hammer, again align the diaphragm bead until the bead touches the housing without deformation.

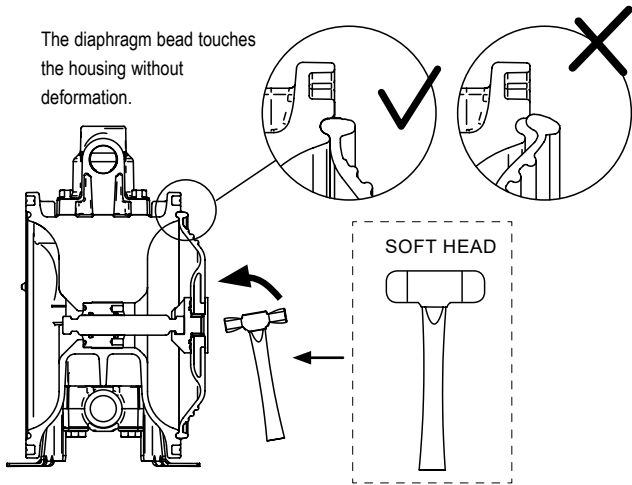

3. DIAPHRAGM COVER INSTALLATION

Place the diaphragm cover and approximate it using the bolts (follow the TIGHTENING SEQUENCE).

Once approximated, torque @132 lbf-in (15 N-m).

**1** CAUTION!: DP200 pump body is fitted with two nipples that fit with two holes in the diaphragm cover to ensure that the cover is placed in its correct position.

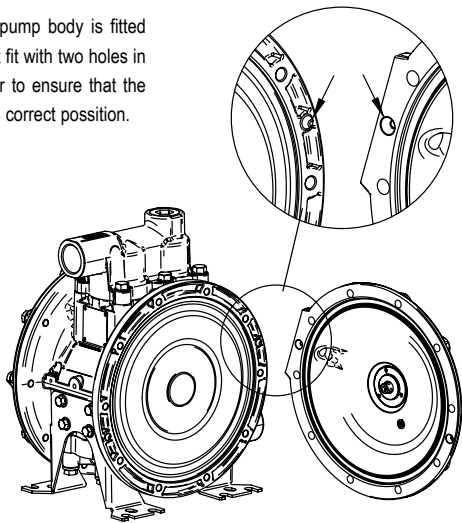

TIGHTENING SEQUENCE

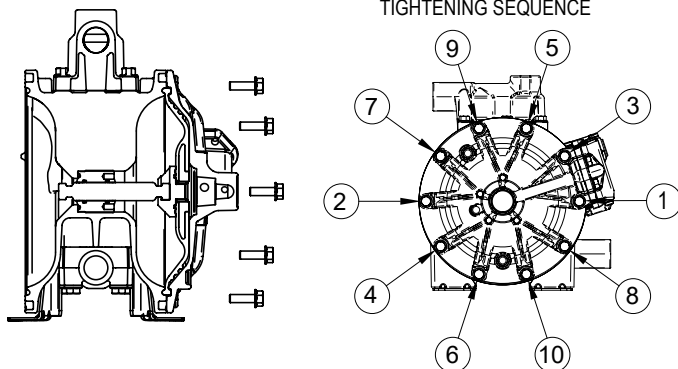

4. CENTRAL ROD RELEASE FOR SECOND DIAPHRAGM ALIGNMENT

Using an air gun fed with 1bar (15psi) maximum air pressure, inject air in the air chamber of the diaphragm cover trough the hole n°1 meanwhile closing the holes n°2 and n°3 . Compressed air will push out the central rod allowing the diaphragm installation without deformation.

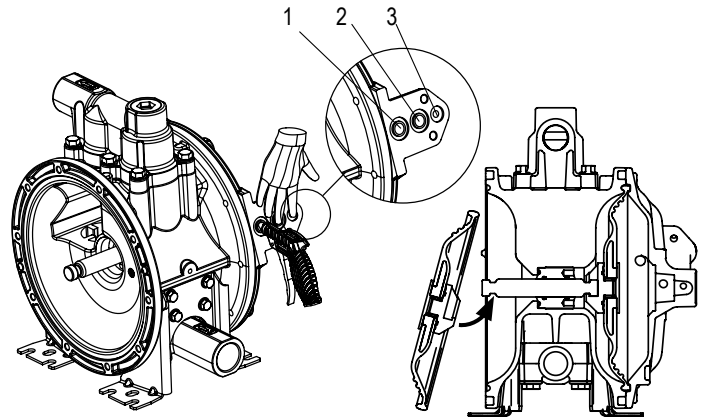

When we hole n°1 is feed with compressed air while closing n°2 and n°3 air enters in the chamber, displacing the central rod and allowing to install the diaphragm.

5. SECOND DIAPHRAGM ALIGNMENT

Install the remaining diaphragm and again, using the soft head hammer, align the diaphragm bead until the bead touches the housing without deformation.

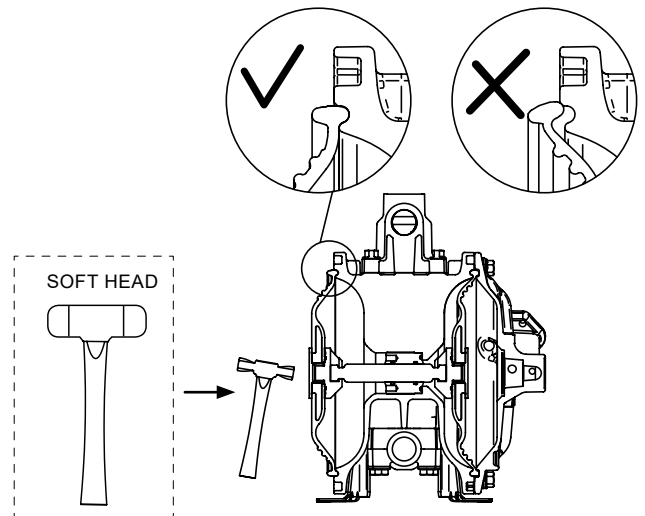

6. SECOND DIAPHRAGM COVER INSTALLATION

Follow same procedure as for the first diaphragm cover described in point n°3.

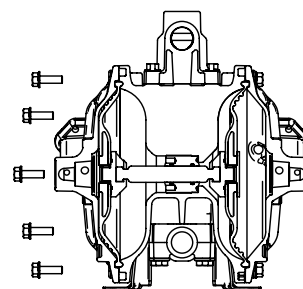

2021\_12\_15-12:00

## REPAIR AND MAINTENANCE PROCEDURES

### PUSHING ROD/CENTRAL BUSHING AND SEAL MAINTENANCE

**NOTE:** Central pushing rod is placed between pump diaphragms.

1. Remove the diaphragms cover on the right side (looking at the pump by the identification plate) as shown in the figure, following the procedure to "Replace diaphragms".
2. Remove the shaft from its housing by pulling it from one end.  
The Teflon® sleeve is threaded into the body. To remove use snap ring pliers in the two holes indicated in the figure.
3. Once the sleeve has been removed, remove the O-ring inside the pump body.
4. Replace the kit following the correct order shown in the assembly drawing. The O-ring between the body and the sleeve may fall during installation, apply mounting grease to attach the O-ring to the sleeve during threading.  
Reassemble the pump in reverse order.

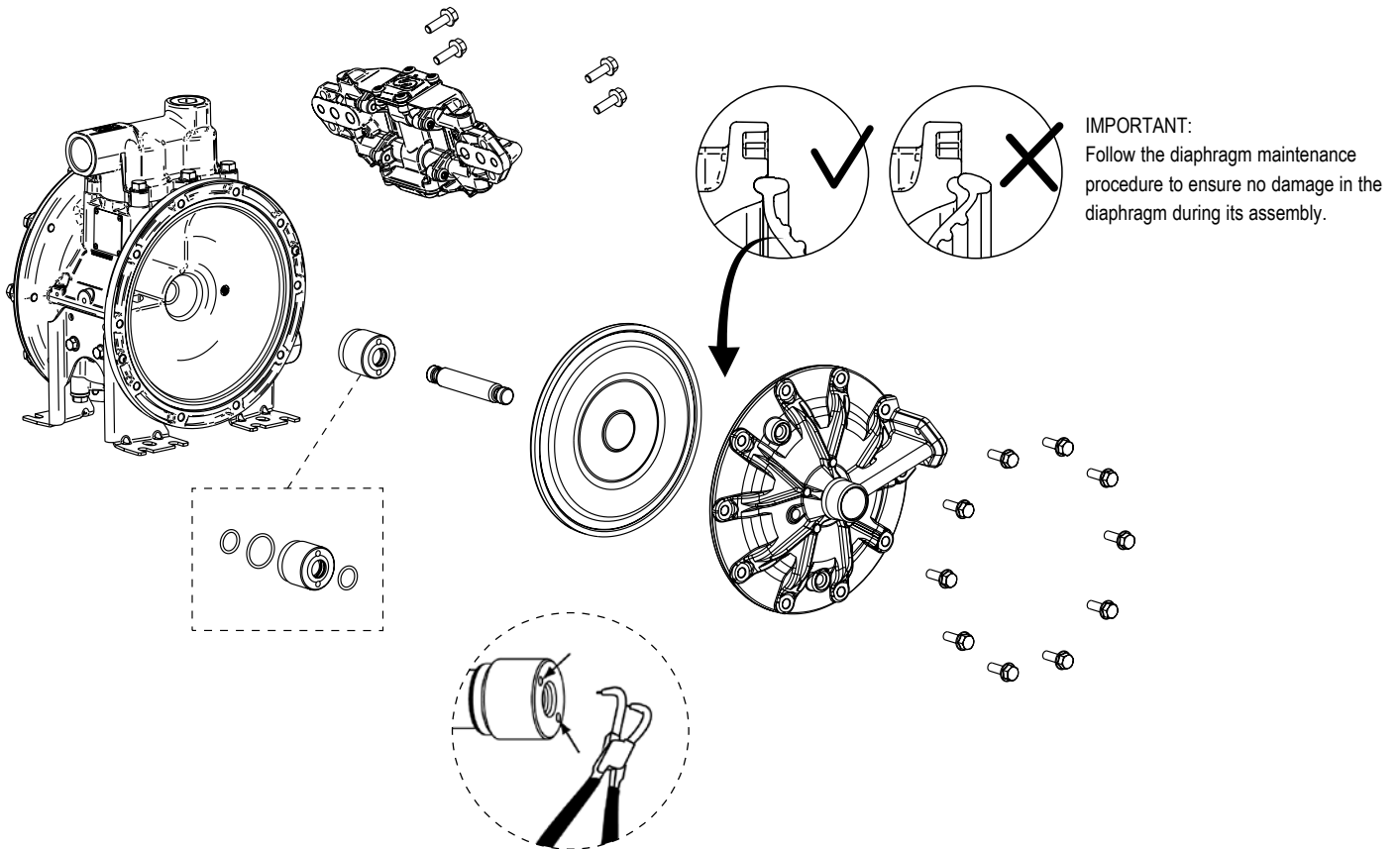

BALL VALVES AND SEATS MAINTENANCE

1. Close fluid valves.
  2. Drain the fluid from inside the pump. Anticipate a drainage of fluid from inside the pump.
  3. Remove the inlet and outlet manifolds. Take note of the orientation of the manifolds.
  4. Install a new set of valves or seats according to these assembly drawings. Tighten the manifold bolts with a maximum torque of 132 lbf-in ( 15 N·m).
- IMPORTANT:** Always approximate manifold bolts before final tightening.
5. Assemble the directional valve being careful not to damage the O-rings and tighten the screws with a maximum torque of 70 lbf-in ( 8 N·m).

**CAUTION!**

**CAUTION WHEN USING PIPE SEALS**  
 DP200 pumps manifold fitted with PTFE (Teflon®) O-ring should be tightened follow the shown sequence.  
 Always tighten bolt (1) and (2), firstly to avoid damage the manifold and the seals.

Outlet manifold bolts  
 25 mm (1") long  
 15 N·m (132 lbf-in)

Hard seat assembly

Soft Seats

This face always downwards

**IMPORTANT:** Soft seats (NBR, Hytel® and Santoprene®) don't need extra seals and the seat is simetric.

Hard seats (PP, POM, PVDF, aluminum, stainless steel), use additional o-rings for sealing. See seat position in the drawing to ensure correct assembly. The bigger diameter o-ring is assembled over the seat and the smaller one below it.

Balls must be always assembled over the seat.

**IMPORTANT:** When doing a pump maintenance that implies manifold disassembling and pump is fitted with PTFE o-rings (white colour), they must be replaced by new ones in order to avoid fluid leakages".

Inlet manifold bolts are  
 50 mm (1.96") long  
 15 N·m (132 lbf-in)

AIR SENSOR MAINTENANCE

The air sensors are on the inside part of the diaphragm covers. To access them, follow the procedure for "Replacing diaphragms".

- Once removed the covers following procedure:
1. Remove the three screws that secure the air sensor to the top.
  2. Remove all components of the sensor. Clean the area.
  3. Introduce new components in the order shown.
  4. Fit the remaining components in reverse order. Fit the side cover and tighten the screws.

AIR SENSOR KIT: 558527

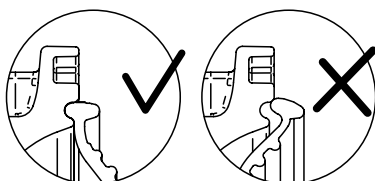

**IMPORTANT:** Follow the diaphragm maintenance procedure to ensure no damage in the diaphragm during its assembly.

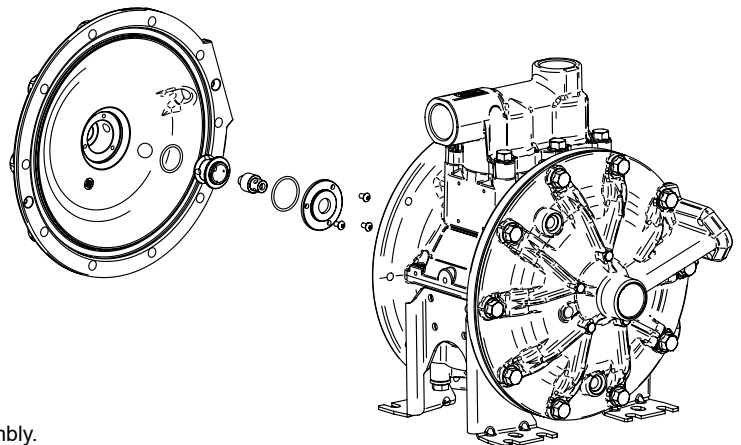



Area with horizontal dotted lines for writing notes.

2021\_12\_15:12:00

EN

Alentec & Orion AB, Grustagsvägen 4, 138 40 Älta, Sweden, declares that the product(s):

**2233X**

conform(s) with the EU Directive(s):

**2006/42/EC**

FR

Alentec & Orion AB, Grustagsvägen 4, 138 40 Älta, Sweden, déclare que le(s) produit(s):

**2233X**

est (sont) conforme(s) à la (aux) directive(s) de l'UE:

**2006/42/EG**

PT

Alentec & Orion AB, Grustagsvägen 4, 138 40 Älta, Sweden, declara que o produto:

**2233X**

cumpra as diretrizes da União Europeia:

**2006/42/CE**

ES

Alentec & Orion AB, Grustagsvägen 4, 138 40 Älta, Sweden, declara que el(los) producto(s):

**2233X**

cumple(n) con la(s) Directiva(s) de la Unión Europea:

**2006/42/CE**

DE

Alentec & Orion AB, Grustagsvägen 4, 138 40 Älta, Sweden, bestätigt hiermit, dass dieses Produkt:

**2233X**

der EG-Richtlinie(n):

**2006/42/EG**

For ALENTEC & ORION AB  
Por ALENTEC & ORION AB  
Pour ALENTEC & ORION AB  
Für ALENTEC & ORION AB  
Por ALENTEC & ORION AB  
От лица компании ALENTEC & ORION AB

**Olle Berglund**  
Product Manager

RU

**Сертификат соответствия:**

ЕАЭК № RU Д-ES.АБ58.В.02842/20, срок действия с 12.08.2020 по 11.08.2025, выдан органом по сертификации продукции «М-ФОНД» ООО «Агентство по экспертизе и испытаниям продукции»; Адрес 125167, Россия, г. Москва, ул. Викторенко, дом 16, стр. 1. Телефон: +74951501658, e-mail: info@mfond.org. Аттестат аккредитации №РА. RU.11АБ58 от 07.04.2016 года.

**Дата производства указана на маркировке изделия**  
**Транспортировка**

Изделие должно транспортироваться в заводской упаковке для защиты от повреждений и влаги.

**Хранение**

Изделие должно храниться запакованным, в хорошо проветриваемом и сухом помещении.

**Утилизация**

Выполняйте национальные правила утилизации и переработки отслужившего оборудования, упаковки и принадлежностей.

**EAC**